



**STRONG PARTNERS.
TOUGH TRUCKS.™**



S1.0 E, S1.2 E SERIES TECHNICAL GUIDE



WWW.HYSTER.COM

> S1.0 E, S1.2 E

			HYSTER			HYSTER				
			S1.0E			S1.2E				
GENERAL	1-1	Manufacturer			HYSTER			HYSTER		
	1-2	Model designation			S1.0E			S1.2E		
	1-3	Drive			Electric (battery)			Electric (battery)		
	1-4	Operator type: hand, pedestrian, standing, seated, order-picker			Pedestrian			Pedestrian		
	1-5	Rated capacity / rated load	Q ₁	t	1			1.2		
	1-6	Load centre distance	c	mm	600			600		
	1-8	Load distance, centre of drive axle to forks	x	mm	728			728		
	1-9	Wheelbase	y	mm	1219			1219		
	WEIGHT	2-1	Service weight		kg	790			801	
2-2		Axle loading with load, front / rear		kg	661	1129		686	1315	
2-3		Axle loading without load, front / rear		kg	568	223		574	227	
WHEELS	3-1	Tyres: polyurethane, tophane, NDIIThane, front/rear			Polyurethane	Polyurethane		Polyurethane	Polyurethane	
	3-2	Tyre size, front	ø	mm x mm	230 x 75			230 x 75		
	3-3	Tyre size, rear	ø	mm x mm	85 x 94			85 x 100		
	3-4	Additional wheels (dimensions)	ø	mm x mm	150 x 50			150 x 50		
	3-5	Wheels, number front/rear (x = driven wheels)			1x+1	2		1x+1	2	
	3-6	Tread, front	b ₁₀	mm	510			510		
	3-7	Tread, rear	b ₁₁	mm	400			400		
DIMENSIONS	4.2	Height, mast lowered	h	mm	1750			1750		
	4.3	Free lift	h ₂	mm	100			100		
	4.4	Lift	h ₃	mm	2380			2380		
	4.5	Height, mast extended	h ₄	mm	2890			2890		
	4.9	Height drawbar in driving position min./max..	h ₁₄	mm	867	1223		867	1223	
	4.15	Height, lowered	h ₁₃	mm	89			89		
	4.19	Overall length	l ₁	mm	1815			1815		
	4.20	Length to face of forks	l ₂	mm	665			665		
	4.21	Overall width	b ₁ /b ₂	mm	790			790		
	4.22	Fork dimensions (4)	s/e/l	mm	55	185	1150	55	185	1150
	4.25	Distance between fork-arms	b ₅	mm	570			570		
	4.31	Ground clearance, laden, below mast	m ₁	mm	50			50		
	4.32	Ground clearance, center of wheelbase	m ₂	mm	29			29		
	4.33	Load dimension b ₁₂ x l ₆ crossways	b ₁₂ x l ₆	mm	1000 x 1200			1000 x 1200		
	4.34.1	Aisle width for pallets 1200mm x 1000mm crossways	A _{st}	mm	2285			2285		
4.34.2	Aisle width for pallets 800mm x 1200mm lengthwise	A _{st}	mm	2245			2245			
4.35	Turning radius	W _a	mm	1426			1426			
PERFORMANCE	5-1	Travel speed, laden/unladen		km/h	6	6		6	6	
	5-1-1	Travel speed, laden/unladen, backwards		km/h	6	6		6	6	
	5-2	Lift speed, laden/unladen		m/s	0.13	0.25		0.12	0.25	
	5-3	Lowering speed, laden/unladen		m/s	0.36	0.31		0.36	0.31	
	5-7	Gradeability, laden/unladen		%	5.8	15.7		5.0	15.5	
	5-8	Max. gradeability, laden/unladen		%	13.8	24.6		12.2	24.0	
ELECTRIC ENGINE	5-10	Service brake			Electromagnetic			Electromagnetic		
	6-1	Drive motor, S2 60 minute rating		kW	1.2			1.2		
	6-2	Lift motor S3 15% rating		kW	2.2kW (S3 5%)			2.2kW (S3 5%)		
	6-3	Battery according to DIN 43531/35/36 A,B,C, no			no			no		
	6-4	Battery voltage/nominal capacity K _s		V/Ah	24V/200Ah (2) (7) (8)			24V/200Ah (3) (8)		
	6-5	Battery weight (1)		kg	185			185		
	6-6	Energy consumption according to VDI cycle		kWh	0.74			0.84		
8-1	Type of drive unit			AC-Controller			AC-Controller			
10-7	Sound pressure level at the driver's seat			dB (A)	66			66		

NOTE:

Specifications are affected by the condition of the vehicle and how it is equipped, as well as the nature and condition of the operating area. Inform your dealer of the nature and condition of the intended operating area when purchasing your Hyster Truck.

- (1) These values may vary of +/-5%.
- (2) Available batteries 24V / 150Ah (144 kg) ; 24V / 200Ah Polypropylene case version (160 kg) ; 24V / 150Ah Polypropylene case version (125 kg)
- (3) Available batteries 24V / 200Ah Polypropylene case version (160 kg)
- (4) With 2 stg mast and b5=570mm the s dimension increases 5mm for first 250mm at toe
- (5) These values are with loadbackrest up
- (6) These values are with loadbackrest down
- (7) Available battery 24V / 100Ah Li-Ion (144 kg)
- (8) Available battery 24V / 200Ah Li-Ion (154 kg)

MAST TABLES

- (1) With free lift of 100 mm.
- (2) All weights are: mast structures (weldment, cylinders, chain, pulley) + oil. EXCLUDED: forks, accessories
- (3) With optional load backrest value is increased of 585mm

NOTICE

Care must be exercised when handling elevated loads. When the carriage and/or load is elevated, truck stability is reduced. It is important that the mast tilt in either direction is kept to a minimum when loads are elevated. Operators must be trained and must read, understand and follow the instructions contained in the Operating Manual. All values are nominal values and they are subject to tolerances. For further information, please contact the manufacturer. Hyster products are subject to change without notice. Lift trucks illustrated may feature optional equipment. Values may vary with alternative configurations.

Specification data is based on VDI 2198

 **Safety:** This truck conforms to the current EU requirements.

TRUCK DIMENSIONS <

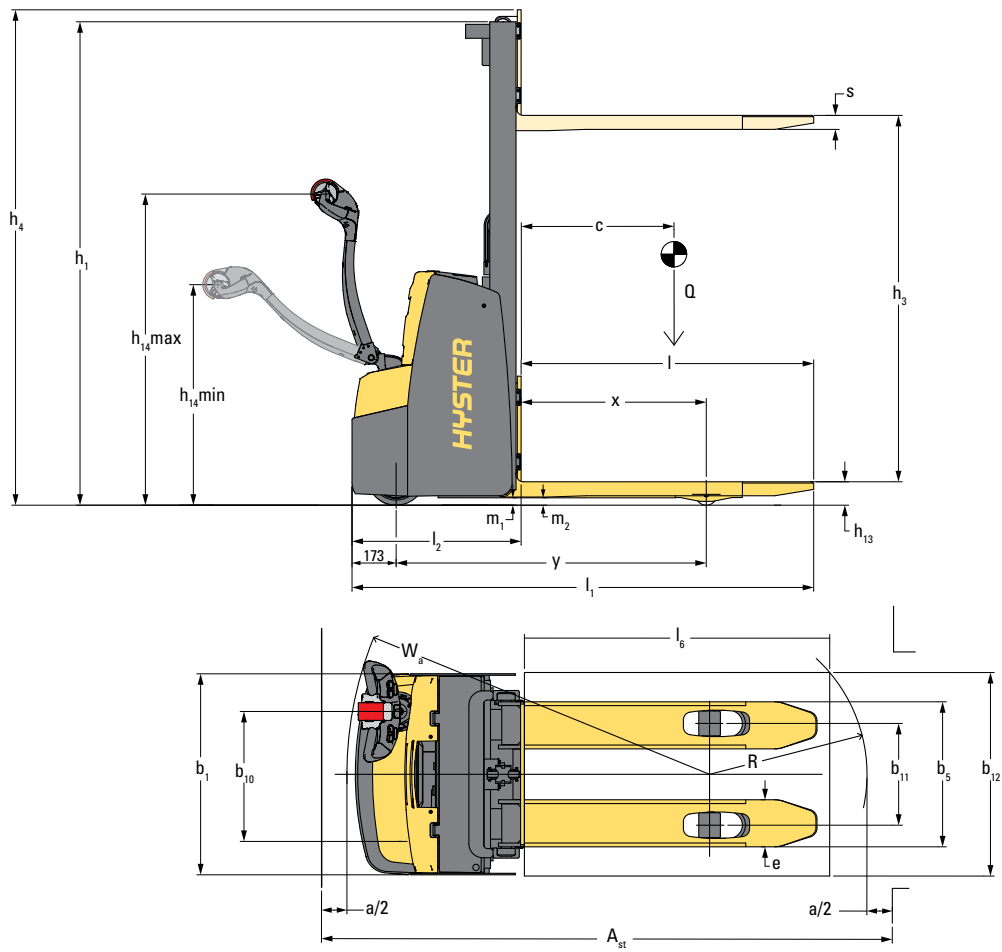

$$Ast = Wa + R + a$$

$$Ast = Wa + \sqrt{(l6-x)^2 + (b12/2)^2} + a$$

$$a = 200$$

MAST TABLES <

1 STAGE FFL

	Lift Height (1) h ₃ (mm)	Height, mast lowered h ₁ (mm)	Height, mast extended (3) h ₄ (mm)	Weight (2) (kg)
S1.0 E S1.2 E	1440	1900	1945	120
	1640	2100	2145	127
	1840	2300	2345	135
	2040	2500	2545	142

2 STAGE NFL

		Lift height h ₃ (mm)	Free lift h ₂ (mm)	Height, mast lowered (1) h ₁ (mm)	Height, mast extended (3) (mm)	Weight (2) (kg)
S1.2 E	S1.0 E	2380	100	1750	2890	188
		2580	100	1850	3090	196
		2780	100	1950	3290	203
		2980	100	2050	3490	210
		3180	100	2150	3690	218
	3380	100	2250	3890	225	
	3580	100	2350	4090	233	
	3780	100	2450	4290	239	
	3980	100	2550	4490	256	
	4180	100	2650	4690	263	

STRONG PARTNERS. TOUGH TRUCKS.™

FOR DEMANDING OPERATIONS, EVERYWHERE.

Hyster supplies a complete range of warehouse equipment, IC and electric counterbalanced trucks, container handlers and reach stackers. Hyster is committed to being much more than a lift truck supplier.

Our aim is to offer a complete partnership capable of responding to the full spectrum of material handling issues: Whether you need professional consultancy on your fleet management, fully qualified service support, or reliable parts supply, you can depend on Hyster.

Our network of highly trained dealers provides expert, responsive local support. They can offer cost-effective finance packages and introduce effectively managed maintenance programmes to ensure that you get the best possible value. Our business is dealing with your material handling needs so you can focus on the success of your business today and in the future.



HYSTER EUROPE

Centennial House, Frimley Business Park, Frimley, Surrey, GU16 7SG, England.

Tel: +44 (0) 1276 538500



www.hyster.eu



infoeurope@hyster.com



[/HysterEurope](https://www.facebook.com/HysterEurope)



[@HysterEurope](https://twitter.com/HysterEurope)



[/HysterEurope](https://www.youtube.com/HysterEurope)



HYSTER-YALE UK LIMITED trading as Hyster Europe. Registered Address: Centennial House, Building 4.5, Frimley Business Park, Frimley, Surrey GU16 7SG, United Kingdom. Registered in England and Wales. Company Registration Number: 02636775.

©2020 HYSTER-YALE UK LIMITED, all rights reserved. HYSTER, , and STRONG PARTNERS. TOUGH TRUCKS. are trademarks of HYSTER-YALE Group, Inc.

NDIIThane is a trademarks of Wicke GmbH + Co. KG.

Hyster products are subject to change without notice. Forklift trucks illustrated may feature optional equipment.